

# CLARKE®



CWB1500D shown

**ENGINEERS WORKBENCH WITH DRAWER**  
MODEL NO: CWB1500D & CWB2000D  
PART NO: 7637718 & 7637807

## ASSEMBLY INSTRUCTIONS

---

## SPECIFICATION

---

	CWB1500D	CWB2000D
Dimensions (w x d x h) mm	1500 x 650 x 978	2000 x 650 x 978
Weight	53 kg	65.8 kg
Maximum Load (table top)	300 kg	
Maximum Load in Drawer	30 kg	
Maximum Load (shelf)	80 kg	
Maximum Load (CD3WB3-drawer unit sold separately)	90 kg	

---

## SAFETY PRECAUTIONS

---

**ALWAYS** seek assistance when lifting heavy items.

**ALWAYS** keep children and animals away from tools and work area.

**ALWAYS** keep work area clean and free from oil spills etc.

**ALWAYS** wear protective footwear when assembling the workbench.

---

## ASSEMBLY

---

Thank you for purchasing this CLARKE product. Please read and follow the instructions carefully. The kit comprises the workbench top, lower shelf, drawer, drawer backstops with screws, and four legs with 16xM8 bolts with nuts and flat washers for the legs.

Unpack your workbench and check to ensure that no damage was suffered during transit. Should any damage be apparent, you should contact your CLARKE dealer immediately.

**The workbench is best assembled with the use of an assistant.**

1. Rest the workbench top upside down on a soft, protective surface and fit the draw backstops to the base using the 4 x M6 screws, washers and bolts.
  - USE WITH CD3WB 3-DRAWER UNIT ONLY

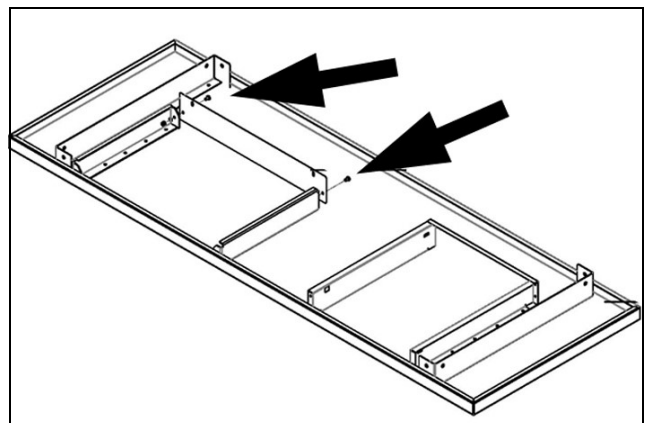

2. At each of the rear mountings, attach a leg, with the foot pad downwards using two M8 bolts with each leg, ensuring a flat washer is used with the nut. Nip up the nuts - DO NOT fully tighten.
3. Attach the front legs in a similar manner using M8 bolts with nuts and flat washers. DO NOT fully tighten.
4. Position the shelf between the legs, using an assistant, and bolt it to the legs, using M8 bolts with nuts and flat washers. DO NOT fully tighten the nuts. NOTE The tray will only fit one way round.

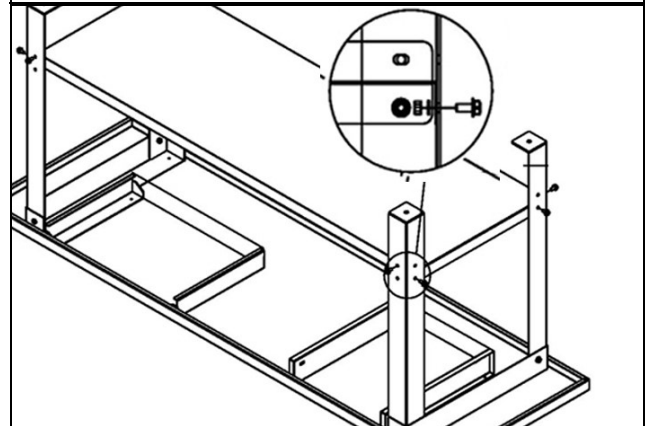
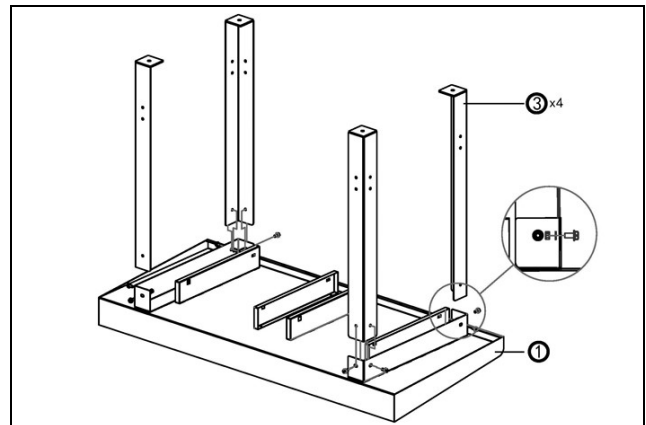

5. Finally, turn the workbench on to its feet on a flat, even surface and shake it vigorously to ensure it is completely stable and resting evenly on all four legs, then fully tighten all nuts.
6. Slot the single drawer into place in the ball bearing draw runners.
7. Please note that if a CD3WB 3-drawer unit is purchased, left/right hand securing brackets are used.

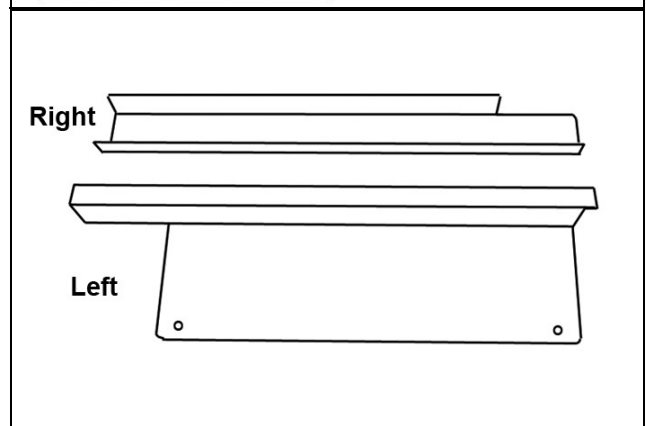
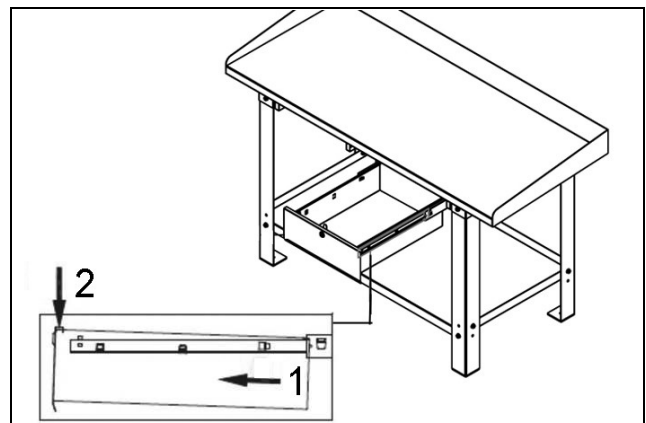

8. Place the unit in position on the lower shelf and bolt the left/right hand securing brackets to the top of the CD3WB using the four bolts/nuts & washers supplied.
9. The locating brackets will align with the drawer supports to retain the drawer unit in position.

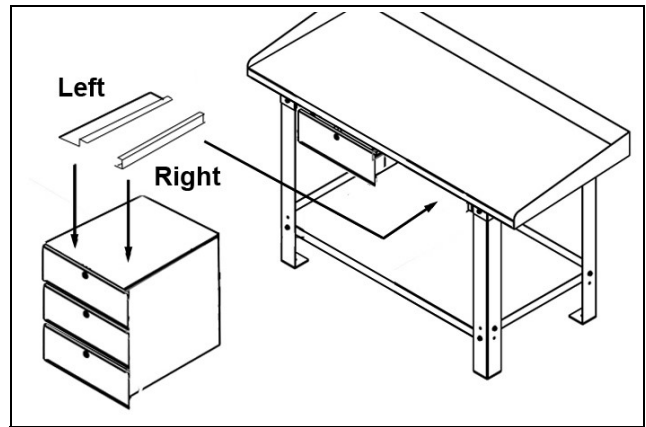

## A SELECTION FROM THE VAST RANGE OF



# Clarke®

## QUALITY PRODUCTS



**AIR COMPRESSORS**  
From DIY to industrial, Plus air tools, spray guns and accessories.

**GENERATORS**  
Prime duty or emergency standby for business, home and leisure.

**POWER WASHERS**  
Hot and cold, electric and engine driven - we have what you need

**WELDERS**  
Mig, Arc, Tig and Spot.  
From DIY to auto/industrial.

**METALWORKING**  
Drills, grinders and saws for DIY and professional use.

**WOODWORKING**  
Saws, sanders, lathes, mortisers and dust extraction.

**HYDRAULICS**  
Cranes, body repair kits, transmission jacks for all types of workshop use.

**WATER PUMPS**  
Submersible, electric and engine driven for DIY, agriculture and industry.

**POWER TOOLS**  
Angle grinders, cordless drill sets, saws and sanders.

**STARTERS/CHARGERS**  
All sizes for car and commercial use.



**Parts Enquiries**  
[Parts@clarkeinternational.com](mailto:Parts@clarkeinternational.com)

---

**Servicing & Technical Enquiries**  
[Service@clarkeinternational.com](mailto:Service@clarkeinternational.com)

---

**Clarke® INTERNATIONAL** Hemnall Street, Epping, Essex CM16 4LG  
[www.clarkeinternational.com](http://www.clarkeinternational.com)